



ROYALTY
CERAMIC

Mingitorio INDUS



Características:

- ④ Mingitorio seco
- ④ Cero olores
- ④ 100% Ahorro de agua
- ④ Cerámica antibacterial
- ④ Sistema doble trampa
- ④ Incluye kit de instalación
- ④ Incluye kit de mantenimiento
- ④ Peso: 18.7 kg

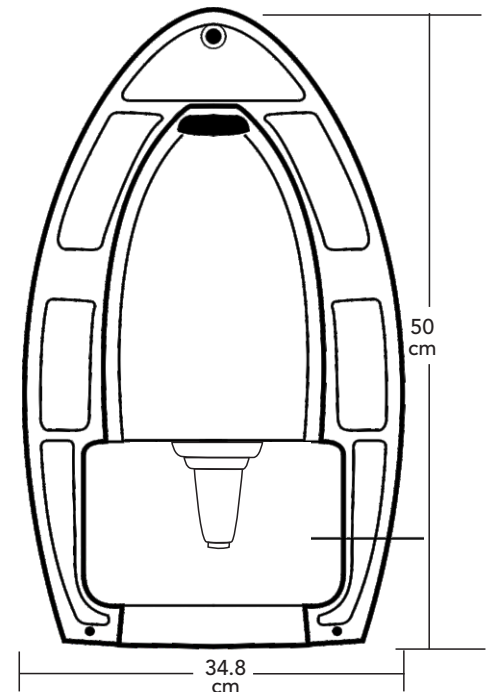
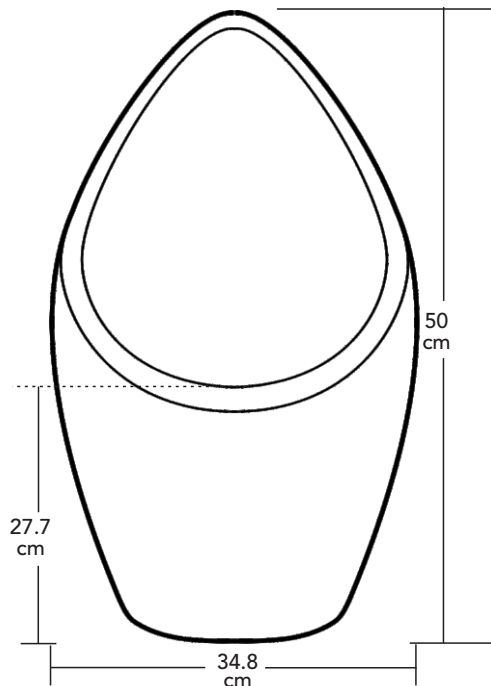
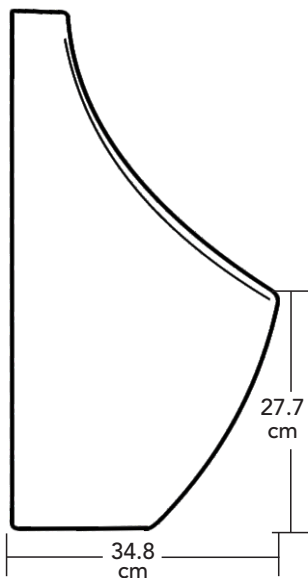

Colores
Disponibles



Blanco

Las dimensiones pueden variar según las tolerancias permitidas de las normas
productos certificados bajo la NOM-002-CONAGUA-2021
www.royaltyceramic.com.mx